

# Flying Flashlight

## Project Plan



May1738

Adviser: Dr. Gary Tuttle

Brady Koht - Team Leader

Joseph Wickner - Co-Team Leader & Co-Webmaster

Peter Bonnie - Group Communicator

Scott Melvin - Document Master

Sebastian Roe - Webmaster

Team Email

<http://may1738.sd.ece.iastate.edu>

Revised: 11/11/16 REV 2

## Table of Contents

<b>1 Introduction</b> .....	<b>2</b>
1.1 Project Statement.....	2
1.2 Purpose.....	2
1.3 Goals.....	2
<b>2 Deliverables</b> .....	<b>3</b>
<b>3 Design</b> .....	<b>3</b>
3.1 Previous Work/Literature.....	3
3.2 Proposed System Block Diagram.....	4
3.3 Assessment of Proposed Methods.....	4
3.4 Design Analysis.....	6
3.4.1 Parts List.....	6
3.4.2 Moving Forward.....	6
3.5 Validation.....	6
<b>4 Project Requirements/Specifications</b> .....	<b>7</b>
4.1 System Specifications.....	7
4.1.1 Functional.....	7
4.1.2 Non-Functional.....	7
4.2 Interface Specifications.....	8
<b>5 Testing</b> .....	<b>9</b>
5.1 Hardware/Software.....	9
5.2 Process.....	9
<b>6 Challenges</b> .....	<b>10</b>
<b>7 Timeline</b> .....	<b>11</b>
7.1 First Semester.....	11
7.2 Second Semester.....	13
<b>8 Conclusion</b> .....	<b>14</b>
<b>9 References</b> .....	<b>14</b>
<b>10 Appendices</b> .....	<b>16</b>

## 1 Introduction

---

### 1.1 Project Statement

The Flying Flashlight team strive to design a portable, hands-free, drone based lighting system. Our target demographic will be varied as well as the implementation of our product. We view our product as a multi-purpose utility light.

### 1.2 Purpose

There are situations in our lives that require light. The purpose behind the Flying Flashlight is to provide a portable lighting system that allows a hands-free experience while providing uninterrupted lighting for an extended period of time.

Possible scenarios include nighttime roadside emergencies. A person may need both hands free to change a tire rather than hold a flashlight. The Flying Flashlight also serves to alert other drivers on the road to the person's whereabouts, creating a safer environment for the time the driver spends outside of the vehicle.

Law enforcement could deploy our product instead of using road flares. Road flares pose fire and safety hazards, especially in dry climates. Road flares also burn for a finite period of time. Flying Flashlight is provided with a battery that far outlasts the burn time of a single flare.

Lighting for backyard activities. Parents can deploy the Flying Flashlight when their children are playing in the backyard where power for lighting may not be available. Light allows children to see and play safely during the twilight hours. Flying Flashlight can even be used for backyard barbecues or any yard activity requiring light where power is not readily available.

### 1.3 Goals

By December 2016 we plan to have a stable, tethered flying platform with a microcontroller (MCU) communicating successfully with an off-the-shelf flight controller. There will be four motors mounted to a laser cut frame. There will also be one mode of lighting. This will be white light provided by the LED's. This will be our proof-of-concept. Powering the device will also be addressed at this stage. The final battery for the system will be determined at a later date. Power will be delivered by tether from a DC power supply.

By May 17<sup>th</sup>, 2017, we plan to have a fully functioning prototype. This includes the tethered drone with LED lighting system, control box, and rechargeable batteries for powering the system. Ideally we will have all batteries contained within the control box.

## 2 Deliverables

---

### By December 2016 end of Fall Semester

- Fabricated and Assembled Drone
- Propulsion System - 4 motors.
- Microcontroller communicating with flight controller - motor control.
- White flood light mode.
- Power provided by tethered external power supply.

### By May 17, 2017 end of Spring Semester

- Final Prototype: Stable hovering LED platform.
- Different LED lighting modes.
- Control box with winch-like system and batteries.
- Operation Manual.

## 3 Design

---

### 3.1 Previous Work/Literature

Quadcopters and drones are a relatively new technology that has risen in popularity in the last few years. As a result, professional knowledge is scarce. Yet, there is no shortage of hobbyist forums and blogs. Tethered drones are even less common despite multiple companies manufacturing drones. Elistair specializes in tethered drones with a focus on aerial surveillance, telecommunications, and traffic monitoring. Elistar uses the tether as a method to power and communicate with the drone. Drone Aviation Corp. has a very similar approach to Elistair, but with a law enforcement and military focus. As a group, we have yet to find an example of a tethered drone for lighting situations.

### 3.2 Proposed System Block Diagram

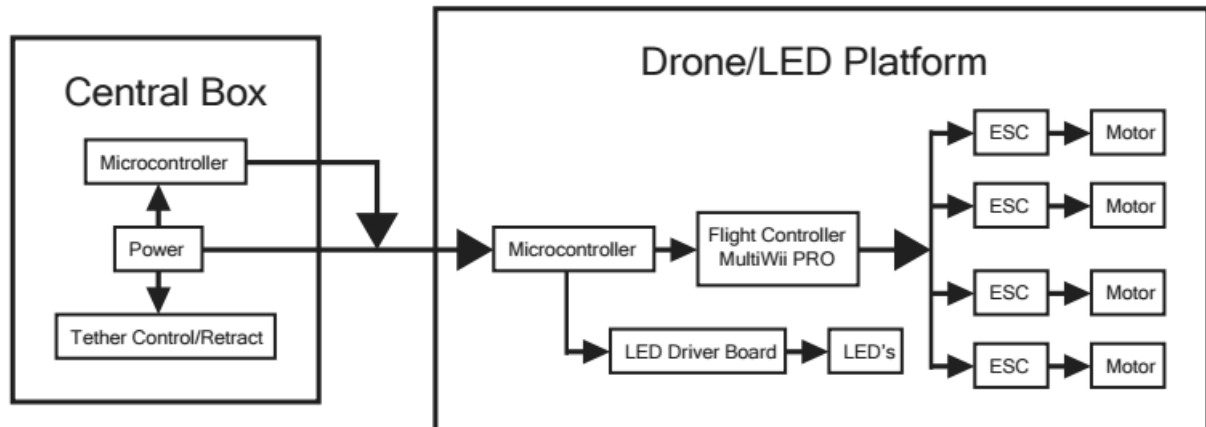

Wireless Communication = RF, Bluetooth  
Wired = Along Side Together

Systems Block Diagram  
Ver. 01  
14.10.2016

### 3.3 Assessment of Proposed Methods

The largest concern of ours is to keep the quadcopter stable. An accelerometer is needed to provide pitch, yaw, and roll data. That accelerometer data is then input and applied to the motors to correct and level the quadcopter. The processes of a flight controller are a senior design project in itself. As a group, we have opted to purchase an off-the-shelf flight controller. There were several options we considered. Our two finalists included the DJI NAZA M flight controller and the MultiWii Pro 3.0. The DJI NAZA is from the well-known quadcopter and drone company DJI. The MultiWii Pro is an open source hardware project that started life as an Arduino and has grown into a familiar hobbyist product. Unfortunately, cost was a major concern for this product and ultimately was one of the deciding factors for choosing the MultiWii over the NAZA. The MultiWii is \$34 dollars and the NAZA M is \$49. This cost is before any GPS attachments. With the GPS, Naza-M is \$79 and the MultiWii is \$52. The vast majority of applications with the Naza-M involves drones being controlled by hobbyists with their remote controls. We are looking to replace the remote control system with a microcontroller to fly the quad to a programmed height without a remote pilot. The MultiWii Pro has a few examples of users interfacing with microcontrollers.

Our application will require a hands-free device. Turn on the control box, select a height and lighting mode, and the drone will fly to that height and stay there dispersing appropriate light. This means we will not have a remote control (transmitter) and a receiver that is typical in a remote control quadcopter system. As a result, we need to replicate the functions of the transmitter and receiver. A microcontroller, acting as a transmitter, will be in the control box sending height and

lighting commands to another microcontroller, acting as a receiver, in the quadcopter. The microcontroller simulating the receiver will need to be able to control the LED lighting system and communicate with the flight controller to power the motors and fly the quadcopter to the desired height. Our first microcontroller choice is the Atmega328 for its low cost and coding language. Wireless and wired communication options are still being considered for this project. RF and Bluetooth are more than capable of handling our communication needs. While power is being provided by tether, adding a few more wires for communication is not difficult and may be less costly.

We wanted a product that was small enough to be easily transportable, yet large enough to be able to handle some slightly windy conditions and potentially heavy lighting hardware. Factoring in these design characteristics, we settled on a medium-sized quadcopter with dimensions around 8 x 8 inches measuring from the center of a propeller to an adjacent propeller. This is roughly similar in size to an industry standard “250-size” quadcopter. With those basic parameters in mind, selecting motors and speed controls was the next step. A typical 250-size quadcopter comes with an 1806 size motor. 1806 refers to a motor stator measuring 18mm in diameter and 6mm thick. Given that our quad would be a slightly larger and potentially heavier platform, we decided on a 2204 size motor from Hobbyking.com. With slightly larger motors, we can produce more torque and lifting force to counteract the extra weight of an LED lighting system. We followed that up with a 20A electronic speed controller as it will provide a safety margin for our motors and is a common size component in the hobby industry.

The control box that the quadcopter is tethered to will contain the power supply for both the box and the quadcopter. A common battery in a 250 size quad is a 3s Lipo battery. A 3s Lipo means there are three cells of lithium-polymer batteries in series. Each Lipo cell has a nominal voltage of 3.7v and 4.2v fully charged. A 3s battery will have maximum charge of 12.6 volts and slowly drop voltage to 11.1 v as the charge is depleted. We can wire several 3s lipo batteries in parallel to provide for longer flight time or we can run this entire system on a 12v source, like a car battery.



A concern we have is heat dissipation with high powered lighting systems. High powered LEDs require heatsinks to dissipate heat and prevent LED damage. Heatsinks add a lot of undesirable weight to the quadcopter. On the positive side, we have 4 motors that provide a lot of airflow over the surface area of the drone to aid in cooling. Vollong is an LED manufacturer that produces several high-

powered options we considered for this project. Vollong makes a linear LED bar option that would be great to mount on each arm of the quadcopter but could add too much weight and uneven heat dissipation with the motors on the very edges of the quad frame. The LEDs we ordered are RGB single bulb style that are smaller in size and will allow a mounting location close to the motors to aid in heat dissipation. RGB LED's allows us to perform several color pattern options to act as emergency lights in a roadside accident, or a white light in a camping scenario.

### 3.4 Design Analysis

Ordered parts have finally been received as of 10/24/16. SolidWorks modelling has begun and completed for components received. This includes the motors, ESC's, LEDs, and flight controller. Quadcopter chassis design is currently underway and the initial chassis has been laser cut from ¼ inch acrylic (See Appendix).

An initial lighting test of the Vollong 3W LEDs showed that a quantity of 4 may not provide sufficient light output to rival the self-design specification of a full size MAG-LITE flashlight. Thus we are suggesting to double the quantity of LEDs to 8. LED control will be provided with microcontrollers. This allows us to independently control the color and operations of each LED.

#### 3.4.1 Parts List

- Quantity 4 of MultiStar Elite 2204 Brushless Motor
- Quantity 4 of Afro Race Spec Mini 20A Electronic Speed Controller (ESC)
- Quantity 4 of 6x4.5 Propeller (2 Clockwise, 2 Counterclockwise)
- Quantity 4 of 5x3 Propeller (2 Clockwise., 2 Counterclockwise)
- Quantity 1 of Multiwii 3.0 Flight Controller with GPS Module
- Quantity 4 of Vollong 3w RGB LED

#### 3.4.2 Moving Forward

Quadcopter chassis and drone assembly/fabrication have been completed, and now flight controller communication, motor, and ESC testing is in development. LED circuit and controller design will occur simultaneously. This necessitates a PCB populated with MOSFET's and resistors required to control the LEDs. A microcontroller will also be implemented on this board. The microcontroller will be responsible for LED control, communication with the control box, and communication with the flight controller.

### 3.5 Validation

The largest concern we have is providing a stable drone. We would like to be able to test our product in windy conditions and simulate disturbances in the lab. We

hope that the drone will not behave erratically and will return to its steady state. We define steady state as hovering at a fixed height and position programmed via our controller. Flight time calculations will be as simple as charging the system and measuring the time it takes the system to power down as a result of low batteries. We would like the amount of light output from the drone to mimic a single 30W light bulb. While we do not have access to light meters, we can use a 30W bulb as a reference. A single 30W fluorescent bulb shares a similar light output to a 3-4.5W LED style light bulb. As we are currently using four 3W RGB LED's, a max of 12W from the LED's should be achievable and should exceed the equivalent 30W standard light bulb.

## 4 Project Requirements/Specifications

---

### 4.1 System Specifications

The system specifications for our senior design project were initially flexible. Dr. Tuttle approached us with an idea that we found alluring; thus we accepted. As such, we decided upon self-policing specifications. They dictate the size of the object be small enough to be portable and large enough to be stable while providing sufficient light output for a finite period of time. Our metric for light output is the equivalent of a full size MAG-LITE, outputting around 168 lumens, while providing at least an hour of operation. MAG-LITE is a robust flashlight kept in homes and automobiles in case of emergencies.

#### 4.1.1 Functional

We will design an LED lighting drone that is tethered to a control box. The control box will supply power and communicate with the drone for flight/hover control as well as lighting modes. The drone will need to be stable in slightly adverse weather conditions including light wind, rain, and potentially snow.

Several lighting modes will be provided in terms of color and illumination patterns. The light fixture can emit red/amber light for emergencies, white light for general purpose lighting, or varied RGB light for festival lighting.

We are aiming for a loiter time of one hour using battery power. We will have to choose a suitable battery to meet this specification. We also want a flight ceiling of seven to ten feet. This will dictate the length of our tether. The gauge of our tether will be dependent on the amount of current the system will draw for powering boards, motors, and LEDs.

#### 4.1.2 Non-Functional

To comply with Federal Aviation Agency (FAA) regulations, research will take place to ensure that the Flying Flashlight does not violate any FAA regulations.



Application for FAA certifications may need to be filed, which may take an unknown amount of time. Other legal documentation may also need to be filed.

One of the final deliverables will be a user manual, which will explain in full detail operating procedures, as well as highlighting FAA regulations to the user. Safety protocols for user operation will also be included.

## 4.2 Interface Specifications

Several different hardware components will be implemented into the Flying Flashlight project. A user must be able to operate the drone with ease. Thus, a simple interface for the user to operate the flight controller must be created. One way our group has proposed to do this is with the following steps:

1. MCU that controls the user interface (in the control box) sends signal to transmitter.
2. Transmitter wirelessly sends data to the receiver on the drone.
3. Receiver sends signal to the MCU on the drone.
4. MCU processes new signal and sends new data to the flight controller and controls the LEDs.
5. Finally, the flight controller sends a signal to the ESCs to spin the motors

To reiterate, accomplishing the steps listed above requires several different hardware components to be interfaced. The MCUs can be low-cost like Arduino, as long as the desired capabilities are available. Since UART is a common mode of communication, the transmitter and receiver connection is probably going to be done using RF communication. Specifically, Digi's Xbee product allows good RF communication while easily interfacing with a product like Arduino.

The final hardware interfacing that needs to be accomplished is the actual user interface. An LCD screen will be provided with an array of buttons. These components will allow the user to set parameters such as flight ceiling and lighting modes. There is no issue interfacing the components with an MCU. It is more up to the coder to create an efficient design that allows for easy interfacing with the MCU. Finally, the MCU needs to be able to interface with the flight controller. Luckily the MultiWii allows PPM which can be created in an MCU.

There really is no software interfacing for this project. However, Atmel Studio, Arduino, Multisim, and SolidWorks are software interfaces we have been using to design, test, and implement our Flying Flashlight. Also, the flight controller has a user interface used to calibrate the chip on the board. This program will be used extensively to ensure the drone is flown safely and correctly.

## 5 Testing

---

### 5.1 Hardware/Software

Standard hardware testing instruments including multi-meters and oscilloscopes will be used to measure, test, and debug any signals. The multi-meter will allow us to see if proper current is flowing and that appropriate voltage drops are seen across circuit elements. The oscilloscope will display communication signals and what bits are being transmitted/received. This will be useful since there is no debug feature on the MultiWii or with the Arduino software. Additionally, a photo sensor of some sort will be used to measure the light emitted from the drone to ensure we are meeting design specifications.

The multi-GUI will serve as a software testing program since there is a monitoring system built in. With the monitoring system we can see if the MCU on the quadcopter is sending the correct signals to the flight controller. If the signal is not correct we can adjust the MCUs code to output the desired signal.

### 5.2 Process

A flowchart located in the appendix shows the sequential order in which we will test the individual parts of our project.

Light output can be measured with a light sensor on a smartphone. We will compare the light output of several different sources, including our drone, street lights, and a full size MAG-Light, commonly used in emergency situations.

Flight stability is a major concern for this project. We will need to be able to simulate flight disturbances. Visual inspection will be enough to distinguish if the quadcopter remains stable. Did the quadcopter crash after the disturbance was introduced? Did the quadcopter return to its origin after recuperating from a disturbance? These are some of the questions we will be addressing during this phase of testing.

The control box communication can be tested using an oscilloscope to see if the correct data is being transmitted. Once it is transmitting correctly, we will send some basic commands to the copter. After successful transmission and receiving of basic commands, we will conduct a flight test where the copter hovers several feet above ground.

Flight controller and motor testing will be accomplished by uploading code to the flight controller and observing if specific motors spool when programmed to. This will occur either through the MultiWii GUI or with the microcontroller sending a PPM signal. This setup will allow for flight controller calibration as needed.

## 6 Challenges

---

There are many factors to consider for the challenges our group will face with completing the Flying Flashlight. Some major concerns, or challenges, have been mentioned previously, but addressed below include: stability in different environmental conditions, designing a cost-effective product, and FAA regulations. Additional items to address are: configuration with the flight controller, mechanical design of the control box, creating a robust frame, and ensuring the ease of use for a non-technical user. Seeing as our group has not had lots of experience in custom drone design, the biggest challenge more than any other will be precise control of the quadcopter when it is airborne.

The challenge of stability control will address drifting, height adjustment, not responding to controls, landing properly, and position readjustment in windy conditions. All of these outcomes must be simulated and tested with the drone to ensure our project is robust. With only one group member being familiar with the operation of drones, and even his experience is limited, the rest of us will have to absorb new concepts and nomenclature fast. As with any engineering, there will be a learning curve we must overcome which is just a matter of time commitment.

Economics will be a major concern in regards to the overall construction of the quadcopter and control box. The idea behind the project is to provide a useful tool that is low-cost so a wide range of consumers can afford to purchase one. Thus, the fabrication cost of the prototype must be kept to a minimum to ensure that the cost of mass production is minimum as well. However, each part must be carefully selected and tested to provide a well-functioning prototype. Obviously, a cost-effective approach to our project will be another great challenge.

The last major challenge our group will face involves the legal aspects of engineering a quad. Over the past couple years, drones have been of great interest to DIYers and concern to the public and government. Thus, many regulations and legal documents have been created so that the public can use drones safely and within legal bounds. Our group must create a product that complies with such regulations so that any consumer in the United States using the Flying Flashlight will not unknowingly be subject to legal ramifications. Some preliminary research will be conducted so that our project does not need to be redesigned when we are near the final iteration of the prototype.

Some other minor challenges that our group will face are reliable communication, robust frame design, and sufficient lighting. First, data must be sent from the control box to the copter accurately. Any missed bits could possibly send the copter flying out of control. Second, if it is the case where the drone is going to fly out of control, the frame must be able to withstand the impact. Since acrylic is our

material of choice, extra mechanical design must be planned to ensure crash durability. Lastly, assuming the copter receives reliable data and is flying correctly, an ample amount of light must be output so the user is content with their application. These concerns are not the greatest challenges to face our group, but each one must be addressed and appropriately designed for.

## 7 Timeline

---

### 7.1 First Semester

1. **Research & Conceptualization – (Week 2 - 5)**  
This phase will take place after the first week of the semester and will continue for 3 weeks. During this phase, research will be performed to determine the best method for fulfillment of our goals.
2. **Parts List Compilation, Review, & Ordering – (Week 5 - 6)**  
During the 5th and 6th weeks of the semester, parts will be researched and ordered.
3. **Preliminary Design Work – (Week 6)**  
During the 6th week of the semester, a frame will be designed to best suit the needs of the project. Several materials will be researched, and an appropriately fitting material will be chosen.  
  
During this phase, any CAD schematics necessary will be made, as well as any design sketches. A method for tethering the Flying Flashlight will also be researched.
4. **Preliminary Website Design & Layout – (Week 6 - 9)**  
During the 6th through 9th weeks of the semester, the design format for the website will be determined and a formal layout will be selected for ideal navigation through the different aspects of this project.
5. **Project Plan – (Week 7 - 8)**  
During the 7th and 8th week of the semester, the group will collectively work on the Project Plan document. This document covers many aspects of the project and is to be as detailed as possible.
6. **Parts Arrival, Design Modification, & Prototyping – (Week 9 – 12)**
  - a. Frame Manufacturing
  - b. Controller Design
    - i. Communication Protocols  
Various methods of communication will be explored, such as wireless via RF, WiFi, and tethered wire communication.

- ii. Calibration
  - Testing and adjustments will be performed to make the drone stable in moderate conditions.
- c. Lighting Fixture Design – Testing
  - i. Building and testing a light fixture for the drone, and deciding on the best course of action moving forward to ensure that the light provided is consistent and sufficient.
- 7. Testing & Implementation – (Week 12+)

Testing the drone, as well as adjusting the controls to make the drone as stable as possible. This will involve a series of field tests in moderate weather situations to determine how best to correct for wind and precipitation.
- 8. Revisions – (Week 12+)

In this phase, any changes from the initial prototype will be made to improve the drone. Potential changes include frame redesign, change of materials/parts, and additional calibrations to compensate for these changes.
- 9. Final Documentation – (Week 13 – 14)

Documentation will be organized over the course of the semester, and final documentation will be compiled in the last two weeks leading up to presentations to ensure that documents presented are up to date with the project, and only relevant documents are included.

## 10. Presentations – (Week 15)

During the second to last week of each semester, the group will present their project. At the first semester presentation, the group will introduce their project to the advisor panel. The group will explain a problematic scenario cultivating the need for a hands-free lighting system.

## 7.2 Second Semester

By the end of the first semester, the group must have a functioning prototype to move forward with improvements and expansions. The early weeks of the second semester will be reserved for the potential need for additional prototyping should the group not meet the original goal. Following this, the timeline will follow a similar pattern to the last half of the first semester.

### 1. Testing & Implementation – (Week 1 - 8)

During the first 8 weeks of the semester new improvements will be made to the drone. Improvements will include new lighting modes, software improvements, and potentially new safety features.

At this stage the drone will undergo further testing to ensure optimal performance. Several tests will be performed to ensure functionality and high quality lighting can be provided in low-light scenarios and moderate weather conditions.

### 2. Revisions – (Week 8 - 14)

This phase will take place during the last 7 weeks of the second semester. At this stage, any final changes to the drone will be made, and the drone will undergo its final testing phase.

### 3. Final Documentation – (Week 13 - 14)

As with the previous semester, documentation will be organized over the duration of the semester, and compiled during the last two weeks. This documentation will include any testing performed, revision records for the drone, bill of materials, and all research performed throughout the duration of the project.

In this phase, the poster board for the public presentations will also be organized and created.

### 4. Presentation – (Week 15)

During the second to last week of the semester the group will present on the final result of the project, including a demonstration (live or video recording) of the drone's performance. During this time, the documentation gathered during the course of 491-492 will also be presented. The group will explain the necessity for the Flying Flashlight, as well as its applications and potential expansions.

## 8 Conclusion

---

The flying flashlight project group plans to create a multipurpose tool that can impact people's everyday lives. Our goal for the first semester is to achieve a stable, level, flying quad copter, tethered to a control box that provides a white flood light. With the progress made so far, we believe this to be achievable. We know there are many features that must be thoroughly designed for such that the end product is robust. Most of these features have been highlighted in the design portion which include stable flight, easy user interface, transportable, long battery life, and appropriate amount of light dispersion. Of course, designing for these features means there will be some challenges along the way.

Any engineering design will always have a set of problems that need to be solved. We have discussed many challenges we consider to be the most pertinent; flight stability, economics, and FAA regulations are the foremost issues that need to be addressed. The drone must be able to fly in the conditions outlined for our project, and affordable for everyday consumers. If these design specifications are not met, this project will not be a marketable item.

Other, less significant issues, such as the LED array, reliable communication, legal documentation, and robust frame design will also need to be designed appropriately. With many design features and challenges to face, our group must stay on time and organized. Therefore, the most important component of the project plan is a timeline. The timeline will guide our group through all phases of design and help us in keeping our schedule.

## 9 References

---

<http://www.instructables.com/id/DIY-ARDUINO-FLIGHT-CONTROLLER/?ALLSTEPS>

<http://www.readytoflyquads.com/multiwii-pro-ez3-0-flight-controller-w-gps-option>

<http://store.dji.com/product/naza-m-lite?from=search>

<http://elistair.com>

<http://www.droneaviationcorp.com>

[http://www.hobbyking.com/hobbyking/store/\\_63065\\_Multistar\\_Elite\\_2204\\_2300KV\\_3\\_4s\\_4\\_pack\\_2\\_CCW\\_2\\_CW\\_.html](http://www.hobbyking.com/hobbyking/store/_63065_Multistar_Elite_2204_2300KV_3_4s_4_pack_2_CCW_2_CW_.html)

[http://www.hobbyking.com/hobbyking/store/\\_80781\\_Afro\\_Race\\_Spec\\_Mini\\_20Amp\\_Multi\\_Rotor\\_Speed\\_Controller\\_with\\_BEC.html](http://www.hobbyking.com/hobbyking/store/_80781_Afro_Race_Spec_Mini_20Amp_Multi_Rotor_Speed_Controller_with_BEC.html)

<https://www.superbrightleds.com/moreinfo/high-powered/vollong-3w-high-power-linear-cob-led/1005/2426/>

<https://www.superbrightleds.com/moreinfo/high-powered/vollong-3w-rgb-high-power-led/899/2214/>



# 10 Appendices

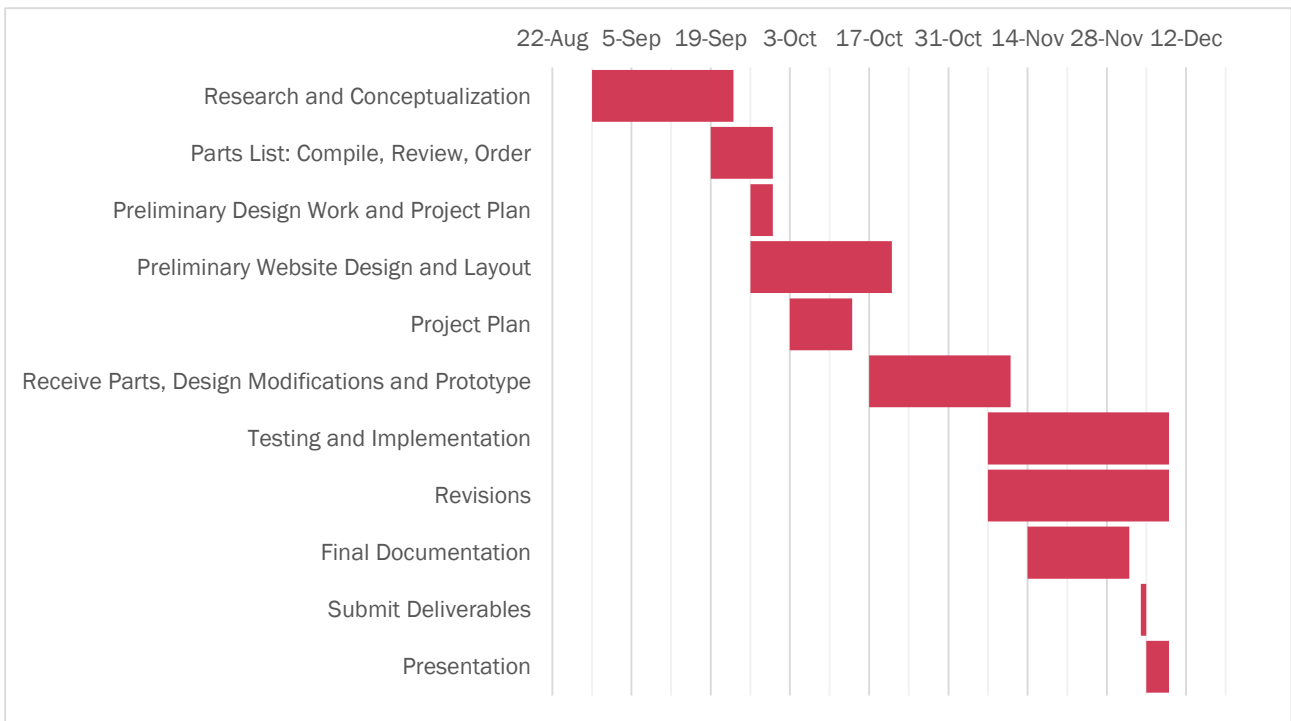

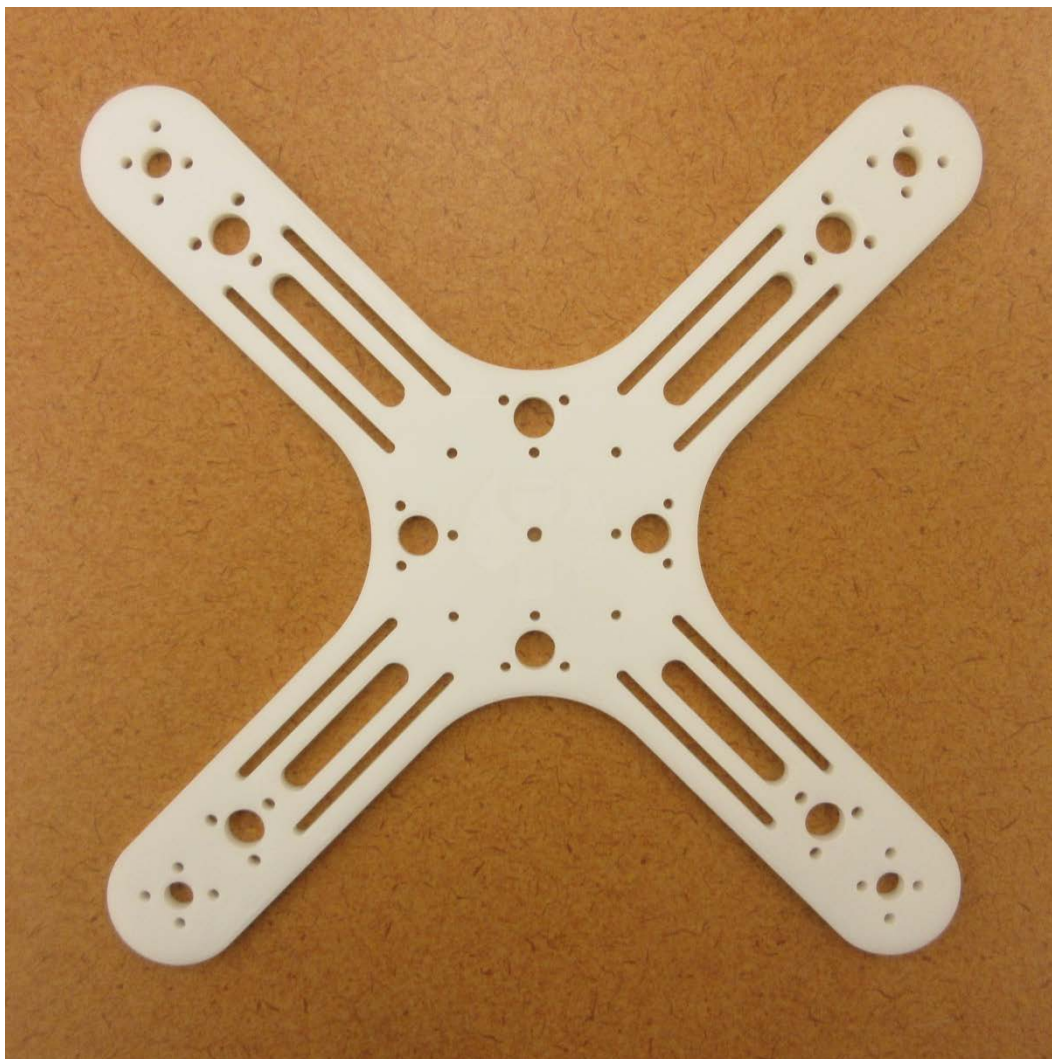

Quarter-Inch Acrylic Laser Cut Chassis.

ISU ECpE Senior Design  
Group: May 1738  
Testing Flowchart Ver. 01

